

Inspection / Service Requirement:

A number of early model parachute swivels were produced with sharp edges which could cut the parachute bridle webbing during a deployment. (The swivel pictured below is the later model, which is not subject to this problem). Early model swivels are aluminum colored, while later models are anodized blue. Not all aluminum colored swivels are subject to this problem, but all swivels which are subject are aluminum colored.

To inspect your swivel, pull the webbing towards the side of the slot and feel the edges along the top of the slot. If they feel sharp, you need to deburr these edges, and also the edges in the corners and on the sides of the webbing slots with a small file. It is not necessary to remove the bridle to do this. You should inspect the bridle during this process for any sign of damage.

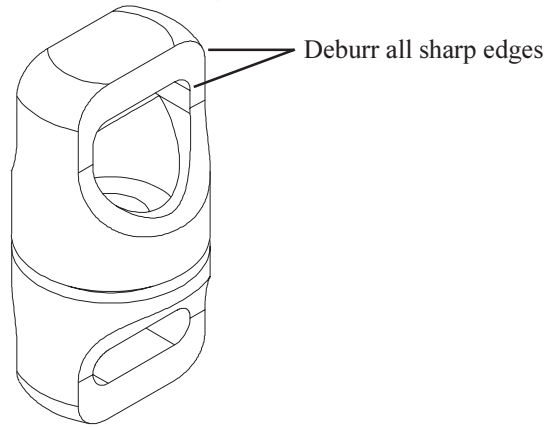

Parachute Swivel

Applies To:

All models equipped with reflex support bridles

Background

For those gliders equipped with reflex support bridles, these bridles are a critical component in the glider's stability system. Proper and precise adjustment of the bridles is critical to ensuring that the glider maintains the levels of pitch stability which were present in the original design and which are required for an adequate level of air worthiness. The bridles do most of their job outside of the normal operating range of angles of attack, however, and therefore there may be no change to the glider's flight characteristics if the bridles are not properly adjusted which would indicate to the pilot that lack of proper adjustment.

Furthermore, there are things which happen naturally in the aging process of the glider which will cause the bridles to go out of adjustment. One of the most important of these is the span wise shrinkage of the sail along the trailing edge, which moves the bridle attachment points inboard with the result that the trailing edge of the sail at the attachment points is lowered, reducing the level of nose up moment induced by this support.

It is therefore necessary that an active program of bridle adjustment maintenance be carried on throughout the life of the glider in order to preserve the proper level of pitch stability for the glider. Failure to do so may render the glider less stable in pitch, and may therefore increase the probability of a pilot induced or turbulence induced loss of control or tumble, or other dangerous incident.

Because of this trailing edge shrinkage, proper adjustment of the bridles cannot be verified on an older gliders by measuring the distance from the top of the kingpost to the bridle attachment point of the trailing edge. This measurement will not change as the sail shrinks, even though the trailing edge will become supported at a lower height as the attachment point moves inboard.

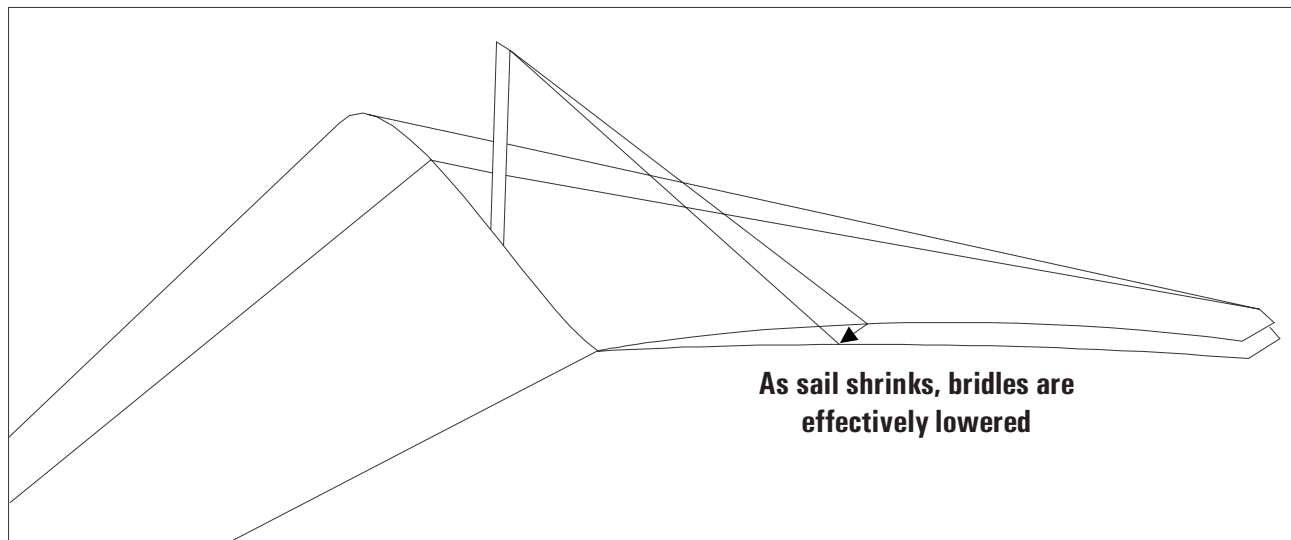

Inspection / Service Requirement

Proper adjustment of the bridles can best be verified by sighting the birdles for slackness in flight. Specific instructions for doing so are included in the glider flight manual. In general, the following applies:

Bridles should not be adjusted looser than "Just Slack" as described below. On gliders equipped with VG, the bridles will be tighter when the VG is tight, and looser when the VG is loose. The just slack criteria would therefore apply to the VG tight adjustment. On some gliders, one or more bridles may be snug when the glider is between VG $\frac{3}{4}$ and VG tight.

In order to sight the bridles, use the following procedure:

For each VG setting (if the glider is so equipped), check the bridles by flying multiple, shallow banked turns at minimum sink speed, sighting the shadow of the bridles on the sail as the glider turns to the proper orientation to the sun.

To sight a bridle line, shake the control bar sharply in pitch with an amplitude of four to six inches. Watch the response of the bridle line, and judge the adjustment as follows:

Tight	No movement in the line, the line is straight and appears under tension.
Snug	Minimal movement, no apparent curve in the line but no apparent tension.
Just Slack	The center of the bow in the line moves one to two inches either side of its rest position. Some apparent curve in the line may be seen without shaking the bar.
Slack	The center of the bow in the line moves two to four inches either side of its rest position. Definite slack in the line can be seen without shaking the bar.
Quite Slack	The center of the bow in the line moves four or more inches either side of its rest position. Slack in the line can be easily seen without shaking the bar.

Improper adjustment of the bridles will affect the glider's pitch stability and flight characteristics in the following ways:

Bridles Too Loose

If the bridles are adjusted too loose, it will not affect the glider in normal flight at VG settings between full loose and VG 1/2, as the bridles are always slack in this range anyway. At VG settings between VG 1/2 and VG full tight, there will be a slight reduction in pitch bar pressure, and a slight increase in maximum sustainable steady state pilot full forward flying speed. At angles of attack below normal flight, there will be a reduction in pitch stability proportional to the amount by which the bridles are looser than they are supposed to be. This stability reduction could increase the probability of a turbulence induced tumble or other in-flight stability related loss of control.

Bridles Too Tight

If the bridles are adjusted too tight, it will compromise the flight characteristics of the glider. The effects of too tight bridles are as follows:

- a) A large pitch trim change from VG loose to VG tight. Normally, the trim speed slows down only by two or three mph between VG loose and VG tight. If the bridles are too tight, to the point where the midspan bridle is going tight as the VG is pulled on, the glider's trim will slow down by several mph and there will be substantial pitch force required to hold the glider out of a stall.
- b) Significant increase in roll control pressures and reduction of roll control rate at VG settings tighter than when the bridles first begin to come tight.

Other factors of glider geometry which affect bridle adjustment and effectiveness

The effective adjustment of the bridles is also affected by other aspects of the glider geometry. For example, if the bottom side wires are too long, it will allow the wings to rise and slacken the bridles in normal flight. If they are too short, it will pull the wings down, and tighten the bridles in normal flight.

If the top side wires are too short, it will reduce the amount the wings can "fold" downwards as the glider unloads at low angles of attack, thereby reducing the effectiveness of the bridles.

Changes from proper length to the top or bottom side wires will also change the relative adjustment of the inner, middle, and outer bridles to each other, and change the way they operate.

Applies to:

Replacement orders

Inspection / Service Requirement:

None

Background:

There are two different sets of 62mm Crossbar Ball and Socket Fittings:

First set:

15J-2110	SOCKET	XBAR CENTER BALL JOINT 62	FITS 60/62 MM
15J-2120	BALL	XBAR CENTER BALL JOINT 62	FITS 60/62 MM

This set is used on the Falcon 195 and Falcon 225.

Second set:

15J-2117	SOCKET	XBAR CNTR BALL JNT 62B	FITS 60/62MM EXTND RANGE
15J-2127	BALL	XBAR CNTR BALL JOINT 62B	FITS 60/62MM EXTND RANGE

This set is used on the XC 132, and has extended range to accommodate VG travel of the crossbar.

This set can be identified by a “2” stamped into the part (shown below).

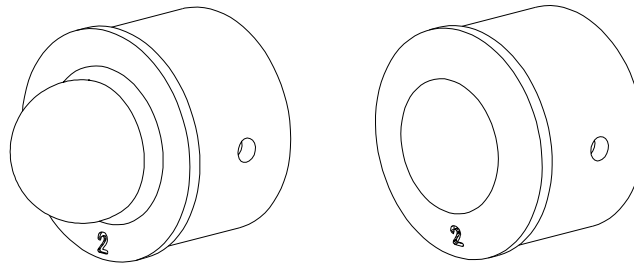

These two types of ball socket joints cannot be interchanged.

Inspection / Service Requirement:

There have been two different types of Fusion main hang loops and each type is subject to this service advisory.

Type 1

The first Fusions used a four strand 7mm accessory cord main hang loop tied with a grapevine knot (as illustrated in the Fusion Owner's Manual). There are two service related concerns with this loop:

- 1) We have had reports of wear on the sheath of the accessory cord where it passes through the hole in the spreader bar.
- 2) We have had reports of the hot knifed end of the accessory cord cutting through the load bearing strand of the accessory cord.

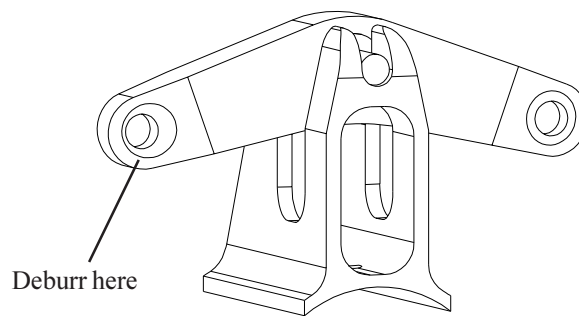

Fusion Type 1 Hang System

Fusion main hang loops of this type must be carefully inspected. If any wear is apparent, the accessory cord must be replaced. If wear is apparent where the cord passes through the hole in the spreader bar, this area of the spreader bar must be thoroughly de-burred to remove any sharp edges.

Type 2

The current Fusions feature a webbing loop mounted to a newly designed spreader bar. The early spreader bars were machined with edges which were not adequately broken in the machining process, and which are unacceptably sharp. As a result, it is possible that during transport of the glider, the loop can be cut or abraded by contact with the spreader bar. Spreader bars of this type on gliders assembled prior to July 7th 1997 must be inspected for sharp edges and carefully de-burred as necessary. Replace any hang loop showing any sign of wear or damage.

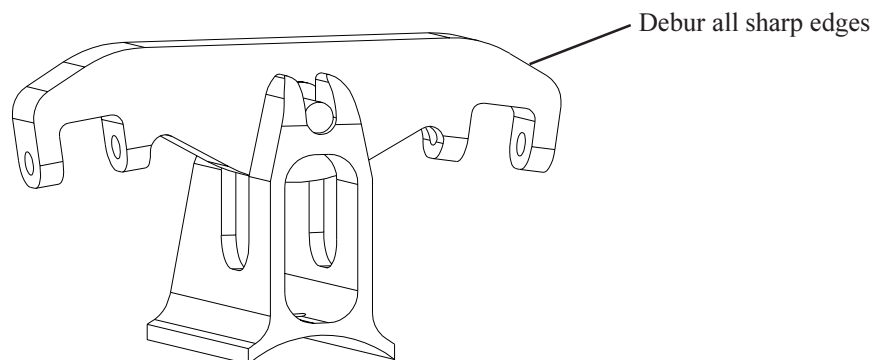

Fusion Type 2 Hang System

Wills Wing has designed a neoprene pad for the cam VG wire junction on Fusions to protect the sail and airframe from damage during packing and transport. If you own a Fusion manufactured before November 1997, you may request a free retrofit pad set for your glider.

There are two different configurations available:

- 1) The pad system on new Fusions is sewn around the perimeter except for three openings for the cables to exit. Retrofitting this system requires disassembling the cam VG cable at the cam VG lever (near the crossbar junction) and at the front pulley block shackle and sliding the pad into position.
- 2) An alternate velcro configuration is provided for retrofit pad sets which can be installed without tools. The best and most secure fit is obtained if the pads are installed with the glider assembled and the VG system activated. If you do not request option 1, we will send you this configuration.

To request your free pad set, please contact Wills Wing and provide your glider serial number.

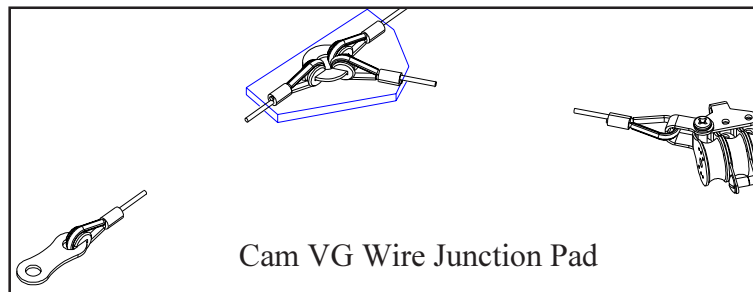

Wills Wing Inc.
500 West Blueridge Avenue
Orange, Ca 92865
Phone (714)998-6359
Fax (714)998-0647
e-mail comments@willswing.com

Applies To:

All Fusions equipped with carbon reinforced sprog assemblies.

Background:

Over the past year, we have encountered several different types of service related failures of Fusion sprog assemblies. As a result, we have made several changes to the sprog design since the initial product release to improve maintenance and durability issues. Most recently, we have completely redesigned the sprog assembly (see below). Since the sprogs are concealed in the sail, and can be deployed without inspection, it is possible for significant damage to remain undetected. It is essential that Fusion owners regularly perform the inspection procedure detailed below.

Inspection Procedure:

Inspect the sprogs, sprog hardware and sprog cables. If the sprogs have been loaded heavily, it is possible that the sprog tubes may have split and the cables may have been stretched.

The normal cable length is 19.5" from hole center to hole center. Any cable which exceeds this measurement by more than 1/16" should be replaced. Also check the attachment tangs for any sign of elongation of the holes. Replace if elongation is found.

Pay special attention to the carbon fiber tubes of the sprog assembly.

Caution - use care when inspecting any carbon fiber part. Carbon fiber splinters can be very dangerous.

Carefully inspect the perimeter of the tubes on both sides of the aluminum knuckle fitting in the middle of the assembly for splitting or cracking. If you suspect any damage to the composite part of the sprogs, remove them from the glider for a more thorough inspection. Note: Sprogs manufactured in 1997 were assembled with a slight downward bow at the center joint. This downward bow is therefore normal, and not indicative of a failure or problem with the sprog.

Inspect the sprog fork, the hinge pillar to which it mounts, and the junction between the hinge pillar and the leading edge bracket for damage and free swiveling both vertically and laterally. Corrosion or tight bolts can cause binding and damage to the fork ears. If necessary, remove the hinge pillar and lubricate the interface to the sprog fork and leading edge bracket with a light coat of white grease. Reinstall the bolts being careful not to overtighten the nuts so as to apply any clamping force.

Inspect the front of the sprog tube at the interface with the threaded insert. In this area, check that the tube is not split or otherwise damaged, that the threaded insert is securely bonded into the end of the tube, that the fork turns freely within the threaded insert, and that the threads are undamaged. We applied a locking compound to the sprog fork threads of early model Fusions. If the threaded assembly does not turn freely, you must remove the sprogs from the leading edge bracket before you attempt to twist or otherwise adjust it, and you must clamp or otherwise secure the threaded insert directly against turning as you rotate the fork. If the sprog tube is, or was ever twisted with stiff or frozen threads, it is possible that the bond between the sprog tube and the threaded insert will have been sheared, allowing the threaded insert to spin inside the sprog tube, and allowing the sprog tube to become detached completely from the insert. Also, the sprog tube or fork may have been damaged. The threads on the sprog fork and threaded insert are very fine pitch, and are easily damaged by cross threading, or by forcing an adjustment when the threads are bound up. If the threads are damaged, these parts must be replaced.

New Sprog Design:

All Fusions manufactured after June of 1998 will be made with a new sprog design, utilizing a new, all 7075 aluminum tube, a new center fitting, a new rear paddle, a new cable, and a new threaded insert and stainless steel threaded fork. These parts, taken together as an assembly, with the addition of a longer bolt to mount the cable to the leading edge bracket, are backwards compatible with all earlier Fusions. In addition, the new threaded sprog fork is backwards compatible with the earlier carbon reinforced sprog tubes (if the original threaded insert is undamaged).

Replacement and Upgrade Options:

We are offering several warranty, replacement, and upgrade options as detailed below. All warranty returns must be made through an authorized Wills Wing dealer, and will be shipped back to that dealer by Wills Wing.

Warranty A

Eligibility: Any failure of a carbon reinforced sprog which occurs within one year of glider delivery date during normal service (no crash landings or other abnormal use).

Wills Wing will repair or replace (at our option) any damaged components without charge and provide return shipping to the customer. If we are out of stock of Carbon Sprog Assemblies, customer will be upgraded to current configuration without charge.

You must return both complete sprog assemblies (everything shown in diagrams 83E03 and 83E07 in your owners manual except the "Bracket LE Sprog Hinge") to be eligible for warranty coverage.

Package and label the left and right side separately. Tape the threaded fork to the sprog tube to prevent it from rotating. Reinstallation may require a complete readjustment of the sprog angle (stability settings) and a test flight by a factory authorized technician or dealer, at your expense.

Warranty B

Eligibility: Any failure of a carbon reinforced sprog which occurs more than one year after glider delivery date, or which is the result of a crash landing or other abnormal use.

Availability: While supplies of replacement parts last. If we are out of stock of replacement parts, you must upgrade to current configuration. See below.

Wills Wing will replace part number 40M-1161 SPROG ASSY - FUSION for \$30 each (33% of the normal retail price). 20G-2440 SPROG FORK ALUMINUM will be inspected, serviced and replaced if damaged for \$7.50 each (33% of the normal retail price) without additional labor charge. Customer pays shipping both ways.

You must return both sides 40M-1161 SPROG ASSY - FUSION (everything shown in diagram 83E07 in your owners manual) to be eligible for warranty coverage.

Package and label the left and right side separately. Tape the threaded fork to the sprog tube to prevent it from rotating. Reinstallation may require a complete readjustment of the sprog angle (stability settings) and a test flight by a factory authorized technician or dealer, at your expense.

Upgrade to current configuration.

Eligibility: Any glider with carbon reinforced sprog assemblies

A sprog upgrade kit, including aluminum sprog tube assemblies, cables, and necessary bolts and nuts for 50% of normal price, or \$75 retail per sprog. Installation will require a complete readjustment of the sprog angle (stability settings) and a test flight by a factory authorized technician or dealer, at your expense.

Additionally, we offer a credit of \$30 retail for the return of both complete carbon sprog assemblies and associated hardware (everything shown in diagrams 83E03 and 83E07 in your owners manual except the "Bracket LE Sprog Hinge").

**Old style carbon sprog 40M-1161
with 20G-2440 fork**

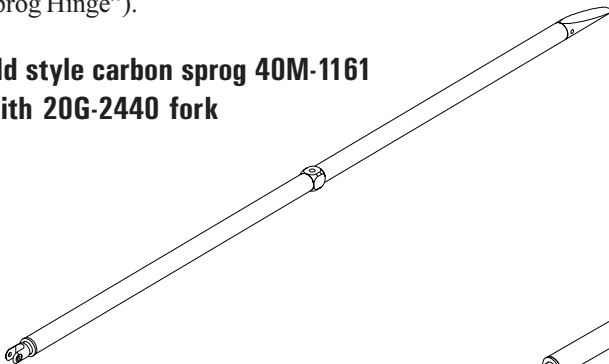

New style aluminum sprog

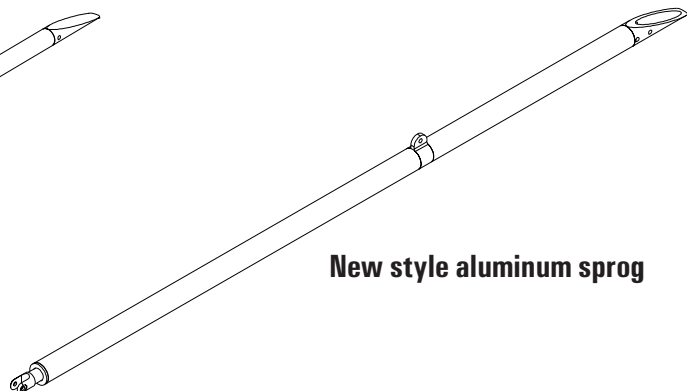

Applies To:

All Fusions equipped with carbon reinforced sprog assemblies.

Background:

Recently, a Fusion owner performing a routine pre-flight inspection reported that the rivets which secure the orientation of the sprog bracket to the back of the leading edge tube were sheared off. The rivet is essential to the structural integrity of the sprog assembly. The cause of the rivet failure is unknown.

Inspection / Service Requirement:

Refer the diagram below. Inspect the rivet fastening the bracket to the backside of the leading edge tube. The 3/16 diameter rivet (part number 10R-0366 Rivet AL 3/16 x .350 Cherry AAPQ6-4) is a high strength 'retained mandrel' type. If the mandrel is missing or the mandrel end is recessed more than 1/16 inches (.063) below the rivet head, the assembly should be considered unairworthy until the rivet is replaced. Replacement rivets are available without charge from Wills Wing. Please include 'Reference TB980709' and your glider number with your request.

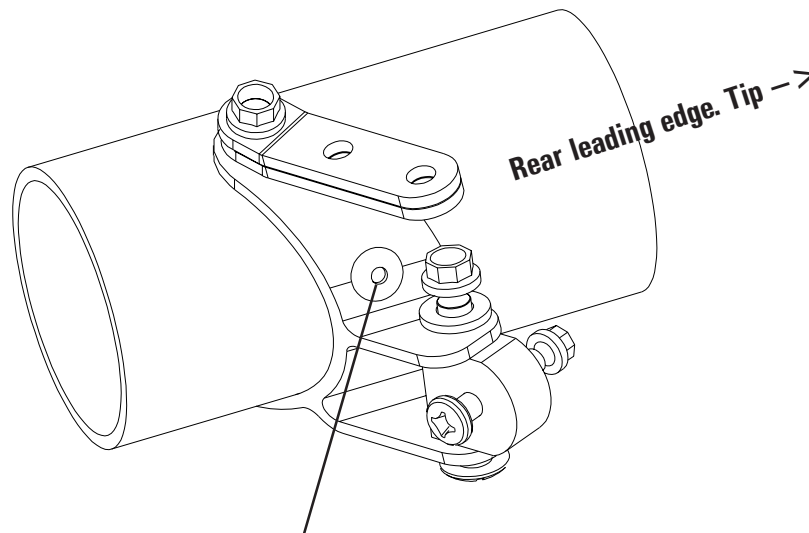

Inspect rivet center for retained mandrel. Replace rivet if mandrel is missing or recessed more than 1/16 inch below surface of rivet dome

Applies To:

All Fusions with rectangular spar assemblies

Background:

Item 45G-3067 Cover Ballistic Fusion Xbar Cntr Plates has been discontinued. It is replaced by:

<u>QTY</u>	<u>ID</u>	<u>Description</u>	<u>Retail Price</u>
2	15P-2011	Poly Netted Sleeve 4" OD x 6"	\$2.25 ea
4	15K-1521	Rivet Plastic 1" Head 3/8" Stem	\$.26 ea

These are the parts used on the round spar Fusions, and they are compatible with the older rectangular spars.

Inspection / Service Requirement:

Replace ballistic cover when it is worn at the edges of the crossbar plates

Installation Procedure:

Tools required:

- Scissors
- Circlip pliers for outside circlips

To install:

Read all directions before beginning.

1. Put the glider up on the control bar and spread each wing 15 degrees.
2. Unzip the bottom surface zipper all the way.
3. Peel back the existing cover to gain access to the large stainless steel pin which connects the root end of the spar to the spar center plates. It is easier to do one crossbar at a time, so that the center wedge doesn't move around.
4. Remove the circlip on the bottom end of the pin.
5. Remove the pin by sliding it out the top of the plates. If the pin binds, move the wing inboard or out a little, or have a helper lift the leading edge at the crossbar junction.
6. Remove the spar from between the plates. (One side at a time).
7. Clip the poly net sleeve 1/2" in from one end, at two places 180 degrees apart in order to make a hole for the plastic rivets.
8. Slide the poly net sleeve onto the spar, with the clipped end towards the keel.
9. Reinstall the spar between the plates, and reinstall the pin.
10. Reinstall the circlip on the bottom of the pin.

Make sure the circlips are properly seated, and have not been deformed during removal and reinstallation.

11. Align the slits in the poly net sleeves with the pin. This will be easier and put less strain on the sleeve if the wings are spread fully open, as if preparing to set up the glider
12. Install the two plastic rivets provided through the holes in the poly net sleeve, and fully into the hollow centers of the pin.
13. Repeat for te other side.

Background:

Folding basetubes manufactured prior to April 1995 have internal safety wires which are incompatible with the wheel compatible control bar basetube brackets. The problem is that the outside dimension of the thimble/wire end of the safety wire is larger than the inside diameter of the wheel compatible control bar basetube bracket.

Installation Procedure:

The following solutions are available:

1. Modify The Wire:

- a. Remove the safety wire by pressing the coil spring pins out of the basetube center plug and pulling the wire out of the basetube.
- b. Carefully squeeze the cable end loop in a padded vise until the outside diameter will fit into the basetube bracket. Do not over squeeze, or the quarter inch bolt will not fit through the thimble.
- c. Reinstall the safety cable.

This service can be performed by the dealer, or by Wills Wing. If done by Wills Wing, there will be a minimal service charge of \$15, plus the cost of shipping the basetube both ways.

2. Replace The Wire:

- a. Remove the safety wire by pressing the coil spring pins out of the basetube center plug and pulling the wire out of the basetube.
- b. Install a new safety cable. (The new safety cables are made with a wire loop at the bracket end which does not have a thimble.)

This service can be performed by the dealer, or by Wills Wing. If done by Wills Wing, there will be a minimal service charge of \$15, a charge of \$24 for the new wires, plus the cost of shipping the basetube both ways.

If either service is performed by Wills Wing, the wheel compatible basetube brackets can be installed at the same time if requested. If the brackets are supplied by the customer, there will be no additional charge for installation. If the brackets are supplied by Wills Wing, the charge for the brackets will be \$45.16.

Background:

Effective July 1998 we have changed the tether assembly which secures the sprog in proper orientation to the transverse batten. The new assembly is both easier to connect and to adjust. There is no requirement to upgrade the earlier configuration to this new configuration.

Upgrade Procedure:

If you wish to upgrade to the new system, an upgrade kit is available for \$20.00 retail. It includes:

2	40P-6051	WIRE SPROG TETHER
2	15R-1311	SNAP CLIP - #798 CLOSED EYE

Note: Fusions manufactured prior to June 1998 generally were fitted with carbon fiber sprogs (black tubes, smaller diameter, aluminum rear paddles). Later models use all aluminum sprog tubes, which have plastic rear paddles. These later sprogs do not have the black bungee cords attached to the paddle. They also do not have the rear neoprene cover installed, as we have found that the plastic paddle will not damage the sail. The bungee cord is not necessary for the function of the sprog, as the combination of the cable tether and the sail rib just inboard of the sprog will insure its proper position. However, without the bungee there is nothing to retain the rear neoprene cover on the sprog, so if you are upgrading carbon fiber sprogs to the new tether system, you may wish to retain the bungee.

Installation:

1. Remove 505 tether and old snap clip from the sail and discard the clip.
2. Install the new tether cable onto the sail by larks heading one end to the loop sewn to the sail as shown.
3. Cut a one foot piece of the 505 leech line to use to attach the new snap clip to the sprog paddle.
4. Attach the clip to the paddle as shown using a single overhand knot inside the paddle cut-out on each end of the leech line. Adjust the length of the leech line loop so as to position the sprog $\frac{1}{4}$ to $\frac{1}{2}$ inch from the fabric rib.
5. If your glider has the new style transverse batten installation where the batten is not enclosed in a full length pocket, larks head an eight inch length of leech line, doubled over, to the sprog tether cable as shown and tape it to the bottom of the transverse batten as shown. This will prevent the cable from wrapping around the batten.
6. Heat seal all cut edges of the 505 leech line.

Note: Due to the small diameter of the cable, it can become disengaged from the snap clip if there is any gap between the hook and gate on the clip. Inspect the clip periodically, and if you notice a gap, adjust the clip as follows:

1. Pull the gate laterally to the side of the hook, and then outward $\frac{1}{4}$ " to $\frac{3}{8}$ " away from the hook.
2. Re-position the gate inside the hook, and verify that it is completely closed.
3. Press the gate inwards as would be necessary to disconnect the cable, and verify that it closes fully when released.

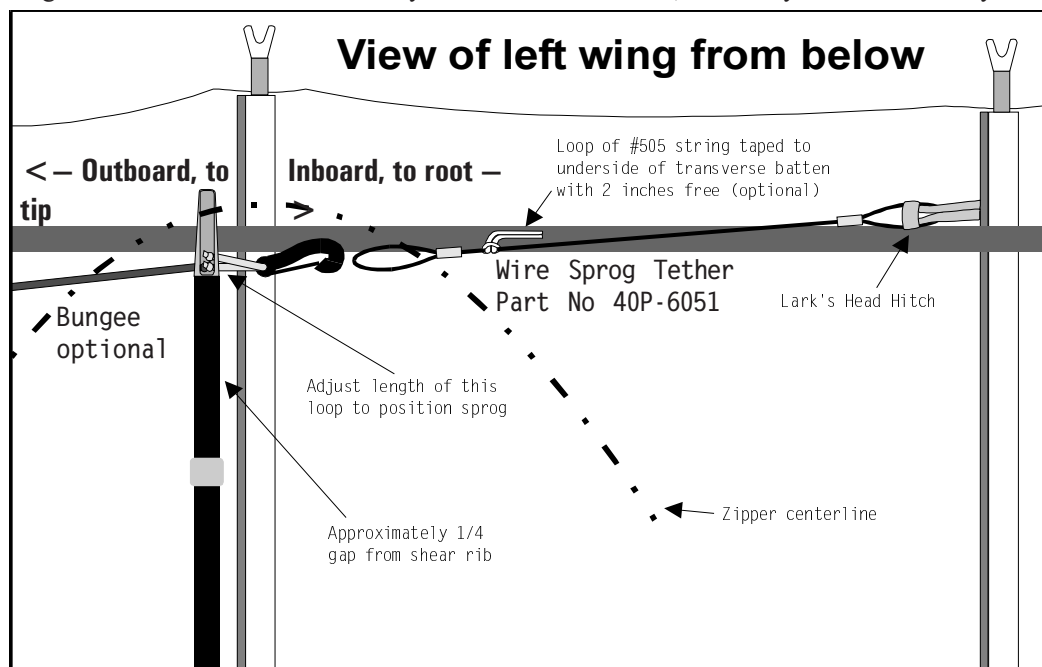

Background:

There have been several design improvements made to the Fusion since the 2nd edition of the Owner's Manual was printed. Please take a moment to consider if any of the following apply to your model.

Leading Edge Pocket / Mylar Insert

The mylar pocket has been changed to make the removal of the mylar insert easier. On new style Fusions the mylar pocket is open to the front so the mylar can be removed without disassembling the glider.

Nosecone Installation

The new style nose cone has no velcro on the back edge. To install the nosecone slide the top rear edges between the mylar pocket and mylar insert. Work it back into position flush with the back edge of the mylar pocket, and then velcro the lower edge into place on the bottom surface. It takes a bit of practice to get it installed cleanly, but you will notice there is no bump caused by the velcro at the back edge.

Transverse Batten Installation

The transverse battens (54 inches long with black heat shrink on the outside) go inside the bottom surface at the back between the #3 batten (second shortest curved batten) and the #5 batten (fourth shortest curved batten). The transverse batten does not need to be removed unless the rear leading edges are removed to "short pack" the glider for transport. Please refer to page 6 in the manual for more information on this.

The new style Fusion sail does not have a batten pocket to encapsulate the transverse batten. During assembly, make sure the sprog paddle supports the transverse batten from the bottom side and is not between the batten and the sail body.

To install the transverse batten slide the end of the batten through the webbing receptacle just inboard of the #3 batten, and then slide it through the webbing receptacle at the #5 rib. Put tension on the batten towards the #5 rib and firmly close the velcro at the #3 receptacle to keep the transverse batten in place. The transverse batten is tapered at each end. The longest (flat) side of the batten goes down towards the bottom surface. The newest Fusion transverse battens are labeled "TOP" on the short side.

You should verify that the transverse batten is seated and properly secured in the end pockets during the assembly sequence and preflight inspection.

Sprog Retaining Cord Without Full Length Transverse Batten Pocket

In April 1998, the full length transverse batten pocket was eliminated and replaced with the system described above which secures the battens only at by ends. The sprog retaining cord can tangle around the transverse batten during transport. Please verify that the cord is not tangled before clipping it to the rear end of the sprog during assembly, and include this additional step in your pre-flight inspection.

Background:

Two pilots have reported locknut assemblies falling off in the last 3 weeks. Both reports involved Ultrasport 166s and the affected assembly was the bottom noseplate front wire anchor. The first pilot discovered the keyhole anchor collar loose in the glider bag. The second pilot had the front wires fall off during the initial take-off roll of an aero-tow. Fortunately, he was not injured. Although both of these incidents involved relatively new 166s, this service advisory applies to all models.

Wills Wing uses four different types of locknuts – clinch nuts, flex lock nuts, nylock nuts and low profile nylock nuts. The most common type on current models is the clinch nut which is the nut shown in the illustrations below. To achieve their locking effect, clinch nuts are deformed in the manufacturing process (two of the flats on the nut are punched inwards) causing them to be too small to fit on the bolt. As they are installed, the bolt stretches the nut elastically, which provides the “clinch” or locking effect. Nylock nuts use a nylon insert which is too small for the bolt to pass through, and which is deformed by the bolt as it is installed producing a similar effect. Flex lock nuts are split at the top in a star like pattern, and flex outwards as the bolt is threaded into this portion, gripping the bolt in the process. All three locking mechanisms provide about 6 to 9 inch pounds torque of locking effect on initial installation on a 1/4” bolt. On nylock type nuts, however, the deformation on the nylon locking insert is largely plastic, (permanent), and therefore the nylock loses much of its locking ability after a small number of installations and removals. (The nylock falls off to 1/2 of its original locking torque after only three installations and removals.) Clinch nuts and flex lock nuts deform almost completely elastically, and therefore retain more of their locking power through multiple uses.

The table below summarizes some of the differences in installation of the different types of nuts. All data in the table, and all references to tightening torque, refer to 1/4 nuts, and all numbers are approximate, +/- 1/2 turn.

	Clinch nut	Flex lock	Nylock	Low profile nylock
Number of turns to thread on until locking effect begins	3 turns	2 3/4 turns	4 3/4 turns	1 3/4 turns
Number of turns after locking effect to obtain one minimum full thread exposed	1 1/2 turns	2 1/2 turns	3 1/2 turns	3 1/2 turns

Inspection and Service Requirement:

Inspect every locknut assembly on the glider. Verify that each bolt has at least one complete untapered thread exposed past the edge of the nut (see diagram 1).

The resistance to turning provided by the locking feature of the nut during installation equates to about 2 lbs of force at the end of a four inch long wrench. Elastic compression of the parts which the bolt and nut are securing may as much as double this force as the nut reaches full tightness. If you need to exert more torque than this, you are over-tightening the nut. If you cannot achieve the minimum one full thread and .036” of engagement as indicated without over-tightening the nut, you must do one of the following:

1. Remove washers, or substitute thin washers for thick washers.
2. Use a flat file to reduce the height of the heads of aluminum bushings to 1/16” (.063”) above the tube.
3. Replace the bolt with a longer bolt.

The “one full thread / .036 inches” criterion is to be used to inspect existing bolt installations. When re-assembling a lock nut onto a bolt, there is an additional criterion which must also be met, in addition to the one full thread requirement – you must have a minimum of one full turn of the nut after the locking feature of the nut engages (after the installation torque reaches at least 6 inch lbs.) If either of these criteria is not met, you must replace the nut and / or the bolt, or alter the assembly configuration until you can achieve both.

In order to help us monitor the extent of this problem, when an assembly situation is found that does not comply with these requirements and requires some change to the configuration in order to comply, please report the details to us.

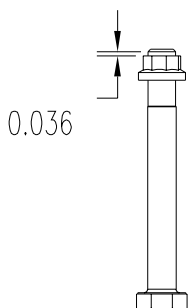

Diagram 1
Nut should have 1 full thread engagement beyond untapered portion of bolt shank. Dimension shown corresponds to 1/4-28 thread.

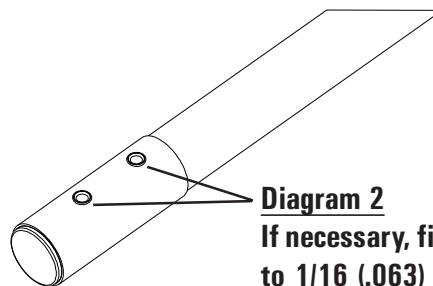

Diagram 2
If necessary, file bushing heads to 1/16 (.063) above tube

Background

Wills Wing gliders manufactured since 1989 have used a part we call the “Keyhole Collar” in combination with a keyhole tang or keyhole channel to secure the bottom front wires to the nose, the top rear wire to the keel, and, on models introduced since 1993, the crossbar sweep wires to the rear keel. Each glider uses two such collars; one on the bottom of the noseplate, and one on the top of the rear keel.

Recently we have seen three incidents of partial failures of this collar. The nature of these failures has ranged from cracks appearing in the part, to a separation of part or all of the “washer” area of the collar from the remainder of the part. In one case, the failure of the collar was coincident with, though apparently not the cause of, the nose wires becoming detached from the noseplate. (The apparent cause of both the wires becoming detached and the failure of the collar in this incident was the fact that the nut which holds the collar on came off of the bolt. See TB# 980716 for more information on this.) As near as we can determine, even a complete, catastrophic failure of the collar would not allow the wires to become detached in flight, so long as the nut remains in place, as either the nut or the head of the bolt (depending on the configuration) would retain the keyhole tang.

However, in our investigation of these incidents we have determined that the part as manufactured is unacceptably brittle, and can be expected to be subject to some probability of failure in normal use. We are therefore recalling all of these parts, and requiring their replacement. We have manufactured new parts out of a different, stronger and less brittle material. The new parts can be distinguished by the color of the plating. The original parts are gold colored 'Cad II' (the same as most AN bolts). The new style replacement parts are silver colored 'Cad I'.

Service Requirement:

Replace both keyhole collars on your glider with new ones. You may obtain new ones through your dealer, or direct from Wills Wing. Please supply the model and serial # of your glider. Note that Falcon 225's use a slightly different collar on the rear keel; it has a wider necked area to accept two keyhole tangs. We will supply parts at no charge on a warranty basis for any gliders manufactured within the last year. We will make the collars available for \$1.50 each (normal retail price is \$3.00 - \$4.50) for gliders more than one year old.

Keyhole Collar

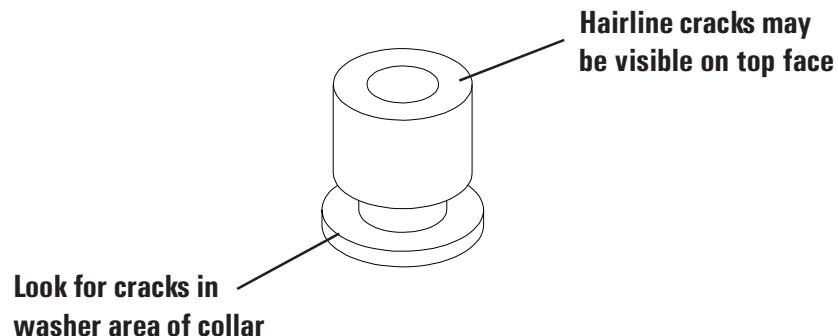

Distorted Mylar Insert And Bridle Cable Snagged Under A Batten

Background:

There are two common set-up errors that, if not corrected during pre-flight inspection, can cause potentially dangerous effects on the glider's flight characteristics.

1. **Distortion Of The Airfoil Caused By Folded Mylar Insert**

While inserting the battens during set up of the glider, it is possible for the tip of the batten, acting through the sail, to catch the rear edge of the mylar leading edge insert, pushing it forward and folding it under in the process. This will cause a raised area of discontinuity in the mylar pocket portion of the leading edge of the wing, which in turn will cause a significant disruption of the air flow. The air flow can be affected over a wide area both inboard and outboard of the actual distortion. The result is that the affected portion of the wing will stall prematurely, at a higher airspeed and lower angle of attack than normal. Consequently, the glider will be difficult to control in the normal minimum sink airspeed range, will tend to stall repeatedly if flown in this speed range, and will tend to fall off into a diving turn towards the affected wing. The glider will exhibit delayed recovery from the stall, and the pilot will experience unusual negative pitch pressures in the control bar.

2. **Bridle Cable Snagged Under A Batten**

It is possible during set up that a bridle cable may end up passing underneath the rear end of the next inboard batten. Because it causes the cable to follow other than a direct route to its attachment at the kingpost, this significantly shortens the effective length of the bridle cable. If this condition is not corrected during pre-flight inspection, the cable will pull up hard on the trailing edge in flight in the vicinity of the batten under which it passes. This will cause the glider to trim slower than normal, and possibly in a stall. It will also cause a turn towards the affected wing, and it will cause the glider to be generally less responsive in roll, and more difficult to control.

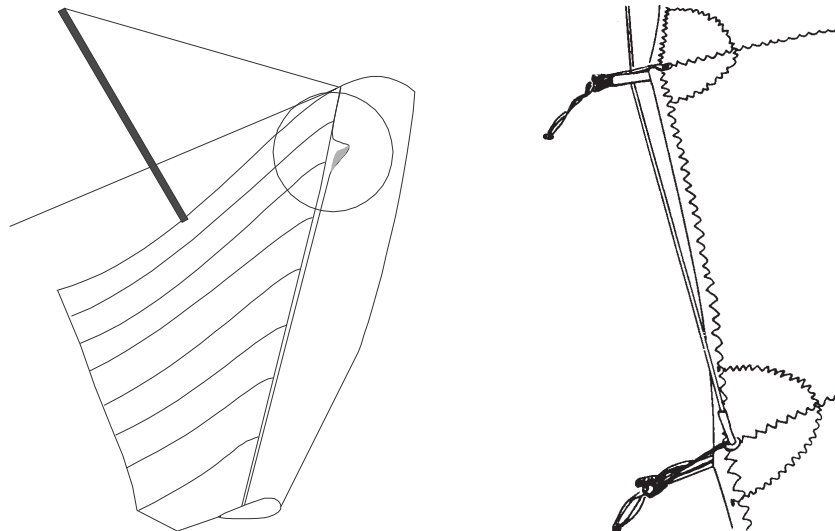

Inspection / Service Requirement:

The primary and preferred solution to either of the above problems is to avoid them by always performing a proper pre-flight.

1. **Folded Under Mylar:**

In the case of a distortion due to folded under mylar, proper pre-flight procedure requires that you carefully sight down the entire length of the top surface of the leading edge, including the full chordwise length of the mylar pocket (the distortion described will tend to occur at the back edge of the mylar pocket, most often towards the root, as illustrated, and it may not be readily noticeable). If you notice such a distortion, de-tension the crossbar, remove the battens in the affected area, smooth down the mylar insert, and re-install the battens.

Distorted Mylar Insert And Bridle Cable Snagged Under A Batten

2. Bridle Under A Batten:

Your pre-flight should always include a full inspection of the glider from the trailing edge. During this inspection, you should check that the bridle balls are properly seated in the grommets, that the bridle ring has not been twisted prior to installation, and that no bridle line passes under an adjacent or farther inboard batten. Note: If for any reason you de-tension the crossbar after doing your pre-flight, you must pre-flight the bridle lines again, as this is a perfect opportunity for a bridle line to become caught under a batten.

Dealing With Configuration Abnormalities In Flight:

Should one of these set up errors occur, and not be discovered and corrected during pre-flight, follow the procedures below for dealing with the situation in flight.

1. **FLY THE GLIDER.** This is the number one rule for any in flight aircraft emergency. Maintain directional control and control of airspeed and angle of attack, and maneuver away from terrain and other gliders immediately.
2. **DETERMINE THE PROBLEM.** While maintaining control of the glider, allow the glider to tell you what's wrong. If the glider is falling off on a wing and repeatedly pitching down, it is likely you have a folded under mylar insert. If the glider is turning one direction and trying to pitch up, it is likely that the problem is a bridle cable under a batten. While maintaining control of the glider, look up at the affected wing (the wing the glider wants to turn towards). Folded under mylar will cause an indicated stall as seen by flow reversal on the tuft on that wing, even though your airspeed is well above the normal stall speed. At the same time, you will feel negative pitch pressure in the control bar if flying near minimum sink airspeed. A bridle cable under a batten will be visible to you as you look along the trailing edge. It can also affect the local flow and therefore the wing tufts, but will usually cause a pitch up tendency, felt as positive pitch pressure in the control bar.
3. **CHOOSE AN APPROPRIATE FLYING SPEED.** If the problem is folded under mylar, fly faster – 30-35 mph. At a higher speed, no part of the wing will be stalled, and the glider will be relatively easy to control and will fly almost normally. If the problem is a bridle cable under a batten, you are better off to fly more slowly, at 22-25 mph, as the turn induced by the batten being pulled up is less at lower speeds. Do not allow the glider to stall, however, as this will compromise your directional control.
4. **CONFIGURE THE GLIDER FOR BEST CONTROL.** If the glider is equipped with variable geometry, set it to full loose. This will afford maximum control authority, and put the most slack in the bridle cables.
5. **FLY TO A SAFE LANDING AREA AND LAND.** If you have a choice, select the largest, easiest landing area. If you have a choice, fly an aircraft pattern away from the turn in the glider. (If the glider is trying to turn right, fly a pattern with all left turns). If possible, go to full upright position with hands on the downtubes early in the approach, so you don't have to change positions at low altitude. Maintain the pre-selected flying speed for best control throughout the pattern, for as long as possible. Do not dive your approach, or slip any of your turns. Instead vary the flight path to control you touchdown point. As you slow down on final, apply an appropriate amount of opposite roll control against the turn as necessary to maintain straight flight. (This will be a continuously increasing amount in the case of folded under mylar.) When flaring to land, apply pitch up control and roll control against the turn simultaneously, and run out the landing.